



# 97KB Ultra Low Cost Flash Smart Card IC

### Environment

- ❑ Voltage Supply Class A, B, C: 1.62V to 5.5V
- ❑ -25 to +85 °C Operating Temperature
- ❑ Max supply current 6mA @ 30MHz, Class B
- ❑ Max supply current 4mA @ 30MHz, Class C
- ❑ > 4 kV ESD Protection HBM (MIL-STD883)

### CPU

- ❑ Software compatible CMOS 80X51 industry standard
- ❑ Accelerated architecture with 16 bit CPU performance level
- ❑ Up to 30 MHz internal CPU clock

### Idle Modes

- ❑ Idle and Stop mode selectable modes
- ❑ NVM update operation with CPU in idle mode
- ❑ IO Transmission and Reception with CPU in idle mode
- ❑ Max Idle current / Clock stopped: 100 uA

### Security

- ❑ Hardware Random Number Generator
- ❑ CRC16 / ISO3309 hardware calculation module
- ❑ Unique chip identification number
- ❑ Notification of tampering
- ❑ IC operates under regulated voltage and internal clock
- ❑ Under / Over voltage sensors (Vcc)

### Memory Control

- ❑ General Purpose Non Volatile Memory: GPNVM
- ❑ Secure Memory Management Mechanism
- ❑ Fast Byte program
- ❑ Fast GPNVM Page Erase

### I/O

- ❑ ISO 7816-3 compliant electrical interface
- ❑ ISO 7816-3 compliant reset and response T=0 T=1 protocols
- ❑ ETU Timer/Counter replacing 8051 T0/T1 Timers
- ❑ Internal software controllable pull-up on IO

### Memories

- ❑ 2048 bytes RAM (256B Local RAM + 1792B XRAM)
- ❑ 96KB GPNVM (User)
- ❑ 1KB GPNVM (System)
- ❑ BootROM loader T0 and GNG compatible
- ❑ 10 year data retention for GPNVM (Flash)
- ❑ GPNVM Memory cycling Endurance > 100 K cycles

### Chip Forms

- ❑ 8" Wafer sawn or unsawn
- ❑ Back grinding and distressing options
- ❑ Wafer thickness according to customer requirement
- ❑ Inkless wafer

### Typical Application:

- ❑ SIM card GSM Phase2+ OTA WIB 32KB
- ❑ 2G, 2.5G, 2.75G, 3G SIM cards
- ❑ Native CDMA / GSM / RUIM / UICC OS 32KB
- ❑ Software compatibility with EMTGXXX

- ✓ *Development tools fully integrated within Keil uVision3/4*
- ✓ *DevKit emulator, examples, documentation samples*

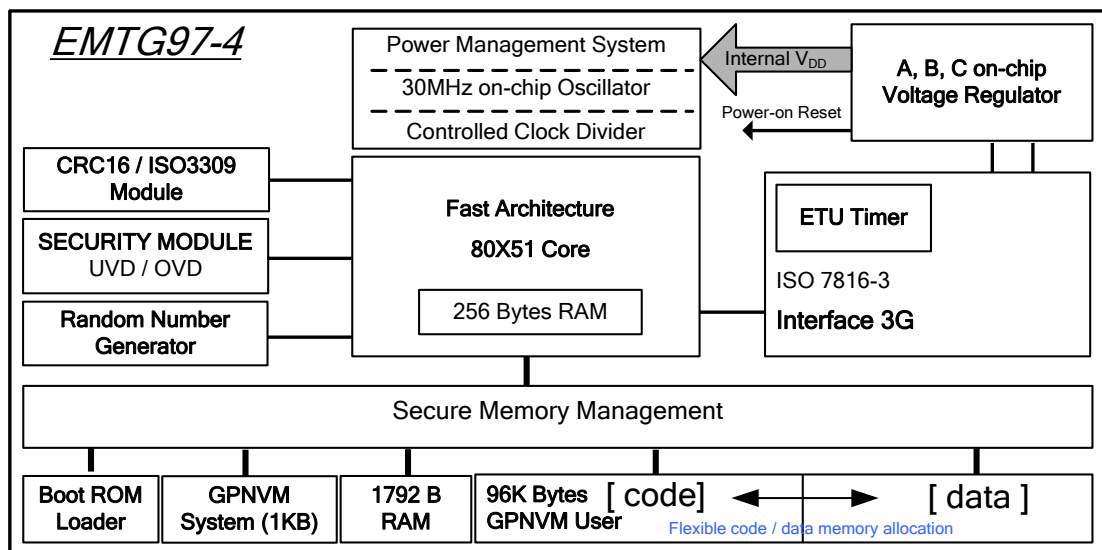



**EM solution benefits:**

- ✓ Powerful architecture combined with Flash flexibility
- ✓ Architecture flexibility : 1 memory
- ✓ Design to cost implementation
- ✓ Total flexibility in term of code / data partitioning
- ✓ Available development tools

**Smart Cards Got Instant**  
Advanced OTP based 8051 smart card IC

**EM46xx True IC Emulation System**

**Fully proven compiler / IDE**

**Generic Emulation platform**

```

005 //*** IC user's application ***
006 void main(void) {
007     //*** IC user's application ***
008     //*** IC user's application ***
009     //*** IC user's application ***
010     //*** IC user's application ***
011     //*** IC user's application ***
012     //*** IC user's application ***
013     //*** IC user's application ***
014     //*** IC user's application ***
015     //*** IC user's application ***
016     //*** IC user's application ***
017     //*** IC user's application ***
018     //*** IC user's application ***
019     //*** IC user's application ***
020     //*** IC user's application ***
021     //*** IC user's application ***
022     //*** IC user's application ***
023     //*** IC user's application ***
024     //*** IC user's application ***
025     //*** IC user's application ***
026     //*** IC user's application ***
027     //*** IC user's application ***
028     //*** IC user's application ***
029     //*** IC user's application ***
030     //*** IC user's application ***
031     //*** IC user's application ***
032     //*** IC user's application ***
033     //*** IC user's application ***
034     //*** IC user's application ***
035     //*** IC user's application ***
036     //*** IC user's application ***
037     //*** IC user's application ***
038     //*** IC user's application ***
039     //*** IC user's application ***
040     //*** IC user's application ***
041     //*** IC user's application ***
042     //*** IC user's application ***
043     //*** IC user's application ***
044     //*** IC user's application ***
045     //*** IC user's application ***
046     //*** IC user's application ***
047     //*** IC user's application ***
048     //*** IC user's application ***
049     //*** IC user's application ***
050     //*** IC user's application ***
051     //*** IC user's application ***
052     //*** IC user's application ***
053     //*** IC user's application ***
054     //*** IC user's application ***
055     //*** IC user's application ***
056     //*** IC user's application ***
057     //*** IC user's application ***
058     //*** IC user's application ***
059     //*** IC user's application ***
060     //*** IC user's application ***
061     //*** IC user's application ***
062     //*** IC user's application ***
063     //*** IC user's application ***
064     //*** IC user's application ***
065     //*** IC user's application ***
066     //*** IC user's application ***
067     //*** IC user's application ***
068     //*** IC user's application ***
069     //*** IC user's application ***
070     //*** IC user's application ***
071     //*** IC user's application ***
072     //*** IC user's application ***
073     //*** IC user's application ***
074     //*** IC user's application ***
075     //*** IC user's application ***
076     //*** IC user's application ***
077     //*** IC user's application ***
078     //*** IC user's application ***
079     //*** IC user's application ***
080     //*** IC user's application ***
081     //*** IC user's application ***
082     //*** IC user's application ***
083     //*** IC user's application ***
084     //*** IC user's application ***
085     //*** IC user's application ***
086     //*** IC user's application ***
087     //*** IC user's application ***
088     //*** IC user's application ***
089     //*** IC user's application ***
090     //*** IC user's application ***
091     //*** IC user's application ***
092     //*** IC user's application ***
093     //*** IC user's application ***
094     //*** IC user's application ***
095     //*** IC user's application ***
096     //*** IC user's application ***
097     //*** IC user's application ***
098     //*** IC user's application ***
099     //*** IC user's application ***
100    //*** IC user's application ***
  
```



**In simulation Profiling Code**



**Flash**

**S/W programmed in flash**

**Introduction**

EMTG97-4 is a member of the Theseus family of devices designed specifically for smart card applications. It is software compatible with the industry standard 8051 micro-controller, to guarantee the maximum availability of qualified software. The hardware implementation of the core is a modern design not relying on microcode, with an increase of up to 4 times on a standard 8051's clocks per instruction.

Security of the family of devices makes them particularly suitable in electronic commerce and sensitive data areas. This is accomplished in hardware, with not only protection against out of parameter operation of the device, but hardware memory management to protect against software security attacks. The CPU clock is derived from its own internal oscillator, so preventing attacks by clock manipulation.

The need to support the emerging multifunction cards requires that the device under software control can download an application and run it when the device is in the field embedded in a plastic card. This application can be in the form of a script to be executed by an interpreter or as a raw binary directly executed by the processor. The device has to be protected against the downloading of attack software designed to corrupt or uncover the working or data contained in the device. Traditionally this has been a software function, which relies on the total integrity of the embedded software. The EMTG97-4 implements the first level of protection in hardware.

A simple and secure memory protection mechanism is relying on a flexible border between code and data space.

The General Purpose Non Volatile Memory concept allows reaching ultra low cost implementation of traditional 64KB EEPROM smart card ICs and more. All your efforts to save code footprint are optimizing your end product performances enlarging data memory.

Best fit for code data partitioning with code size + NV data size < 96KB.

**Serial interface**

EMTG97-4 offers a unique serial interface compliant with the ISO 7816-3 specification with several modes implemented allowing serial connections at 9600 up to 357K bits per second at 3.57MHz. EMTG97-4 supports T=0 asynchronous half duplex character transmission protocol, T=1 asynchronous half duplex block transmission and a proprietary T=14 protocol used for fast loading of Code by card manufacturer. It handles minimum guard time requirements between characters specified by ISO7816-3 specification automatically. EMTG97-4 is designed to be compatible with the ISO7816-3 specification defining the characteristics of Integrated Circuit Cards commonly referred to as smart cards.

**Random Number Generator**

The on chip random number generator is passing test based on FIPS140-2 criteria, providing a rapid stream of random numbers. This allows use of the random numbers generated beyond just the provision of numbers for authentication, randomising transmissions or session key generation.

**Clocks**

EMTG97-4 has its own internal oscillator this allows the core of the device to be independent of the external clock. The processor can also be clocked much faster than the IO CLK signal. The internal clock generator is connected to the core via a divider that is under the control of the software. This allows the Operating System writer to control the trade off between execution speed and power drawn by the device. Extending battery life in hand help applications where slow interfaces are involved.

**Anti tampering**

The EMTG97-4 has extensive anti tampering provision including the monitoring of the connection to the device to ensure that deviations beyond a prescribed criteria result in the device being closed down before its operating conditions are violated.

**On chip voltage regulators**

Several on chip regulators isolate the various elements of the device from variations and fluctuations in the supply voltage. This allows elements to be characterised precisely, as they operate at one fixed voltage, which in turn maximises the endurance of the device.

**Technology**

This product is using superior Flash memory SuperFlash Technology licensed from SST and SuperFlash is a registered trademark of SST (Silicon Storage Technology Inc.).



## Technical Data

## Absolute Maximum Ratings

Parameter	Symbol	Limit Values			Unit
		min	typical	max	
Supply Operating Volt	$V_{CC}$	-0.3		6	V
Voltage at remaining pin	$V_{pin}$	$V_{SS} - 0.3$		$V_{CC} + 0.3$	V
Power dissipation	$P_{tot}$			+60	mW
Storage temperature	$I_{ccl}$	-40		+125	°C

## DC Characteristics

Parameter	Symbol	Limit Values			Unit
		min	typical	max	
Operating temperature	$T_A$	-25		+85	°C
Supply Voltage Class A,B,C	$V_{CC}$	1.62		5.5	V
Supply Current Class C	$I_{CC}$			4 (Note 1)	mA
Supply Current idle	$I_{ccl}$			200 (Note 2)	μA
Supply Current stopped	$I_{CCS}$			100 (Note 3)	μA

Note 1: The supply current refers to clock frequency of 5 Mhz

Note 2: The supply current at 3.3V and a clock frequency of 1 Mhz, at +25 °C

Note 3: The supply current at 3.3V at +25 °C

## IO pin:

Parameter	Symbol	Conditions	min	max	Unit
H input voltage	$V_{IH A, B, C}$	$I_{IHmax} = \pm 20 \mu A$	$0.7 * V_{CC}$	$V_{CC} + 0.3$	V
L input voltage	$V_{IL A}$	$I_{ILmax} = \pm 20 \mu A$	-0.3	0.4	V
	$V_{IL B, C}$		-0.3	0.3	V
H output voltage	$V_{OH}$	$I_{OHmax} = +20 \mu A$	$0.7 * V_{CC}$	$V_{CC}$	V
L output voltage	$V_{OL}$	$I_{OLmax} = -1 mA$	0	0.3	V
Rise Fall Time	$t_R, t_F$	$C_{IN} = C_{OUT} = 30 pF$		1	μS

## Clock (CLK)

Parameter	Symbol	Condition	Min	Max	Unit
H input voltage	$V_{IH}$	$I_{OHmax} = +20 \mu A$	$0.7 * V_{CC}$	$V_{CC}$	V
L input voltage	$V_{IL A}$	$I_{OLmax} = -20 \mu A$	-0.3	0.5	V
	$V_{IL B, C}$		-0.3	$0.2 * V_{CC}$	V
Rise Fall Time	$t_R, t_F$			9% CLK period	

## Reset(RST)

Parameter	Symbol	Condition	Min	Max	Unit
H input voltage	$V_{IH A}$	$I_{IHmax} = +20 \mu A$	$0.7 * V_{CC}$	$V_{CC} + 0.3$	V
	$V_{IH B, C}$		$0.8 * V_{CC}$		V
L input voltage	$V_{IL}$	$I_{ILmax} = -20 \mu A$	-0.3	0.6	V
			-0.3	$0.2 * V_{CC}$	V
Rise Time	$t_R$			400	μS
Fall Time	$t_F$			1	μS

EM Microelectronic-Marín SA (EM) makes no warranty for the use of its products, other than those expressly contained in the Company's standard warranty which is detailed in EM's General Terms of Sale located on the Company's web site. EM assumes no responsibility for any errors which may appear in this document, reserves the right to change devices or specifications detailed herein at any time without notice, and does not make any commitment to update the information contained herein. No licenses to patents or other intellectual property of EM are granted in connection with the sale of EM products, expressly or by implications. EM's products are not authorized for use as components in life support devices or systems.